

Self Regulating Heating Cable

11A (HSR)



TRACELEC 
HEATING SOLUTIONS

11A (HSR)

SELF REGULATING HEATING CABLE

1. DESCRIPTION



11A self-regulating heating cables provide a power that varies depending on the process temperature. When the temperature drops, the emitted power increases. When the temperature increases, the power of the cable decreases. This prevents hot spots when two cables overlap. This system also adjusts for temperature variations due to stagnant fluids and height differences (vertical pipes).

11A cables are commonly used in construction or industry in non-corrosive environments. Exposure to aqueous inorganic chemicals.

2. CABLE SELECTION

Model	Nominal power	Temperature	Voltage
11A102	10 ~ 14 W/m	10°C	230 Vac
11A162	16 ~ 20 W/m	10°C	230 Vac
11A242	24 ~ 28 W/m	10°C	230 Vac
11A302	30 ~ 34 W/m	10°C	230 Vac

3. CONSTRUCTION

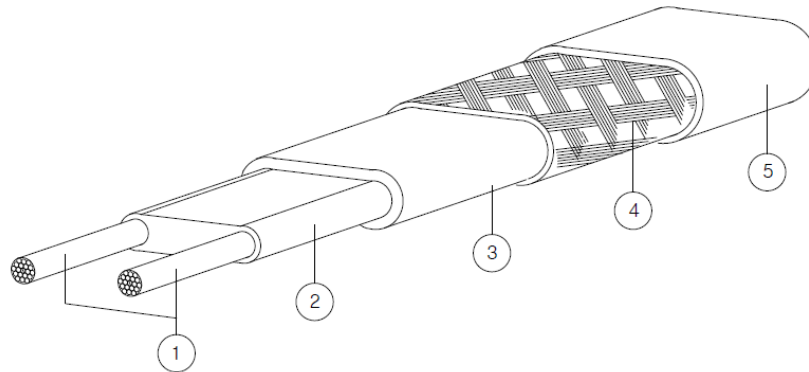

Parts	Construction	Material	Notes
1	Conductors	Nickel-Plated Copper	7/0.45, 1.1mm ²
2	Heating element	Polyolefin + C/B	
3	Inner insulation	FR Polyolefin	
4	Ground braid	Copper ground braid	10/0.12*16, Coverage: 80%
5	Outer jacket	FR Polyolefin	

11A (HSR)

SELF REGULATING HEATING CABLE

4. FEATURES

- Cables can be overlapped without creating hot spots or causing a burn out
- It automatically adjusts heat output based upon exposure temperature
- It can be cut to any length in the field
- It adjusts its output to independently respond to ambient temperatures all along its length
- Energy efficiency which extends the life of the cable
- Connection and end termination kits easy to install

5. USE

11A heating cables are mainly used for:

- Water lines freeze protection
- Industrial maintenance temperature
- Ordinary and hazardous locations (Ex e IIC Gb, ATEX certification)

6. ESPECIFICACIONES TÉCNICAS

Description	Data
Voltage	200 ~ 277 Vac
Ambient temperature	$-20\text{ °C} \leq T_{\text{amb}} \leq 40\text{ °C}$
Minimum installation temperature	-20 °C
Maximum maintain temperature (power on)	65 °C
Maximum exposure temperature (power off)	85 °C
T-rating	T6 (85 °C)
Impact resistance	13.6 J @ -20 °C
Bus wire	ASTM B355 Class 2 NPC 16 AWG
Dimensions (aprox.)	11A102 11.4 ± 0.2 mm x 5.4 ± 0.2 mm
	11A162 11.4 ± 0.2 mm x 5.4 ± 0.2 mm
	11A242 11.4 ± 0.2 mm x 5.4 ± 0.2 mm
	11A302 13.4 ± 0.2 mm x 5.4 ± 0.2 mm
Minimum bend radius	35 mm @ -20 °C
Standards	EN 60079-0
	EN 60079-7
	EN 60079-30-1

11A (HSR)

SELF REGULATING HEATING CABLE

7. NOMINAL POWER OUTPUT RATING ON METAL PIPES

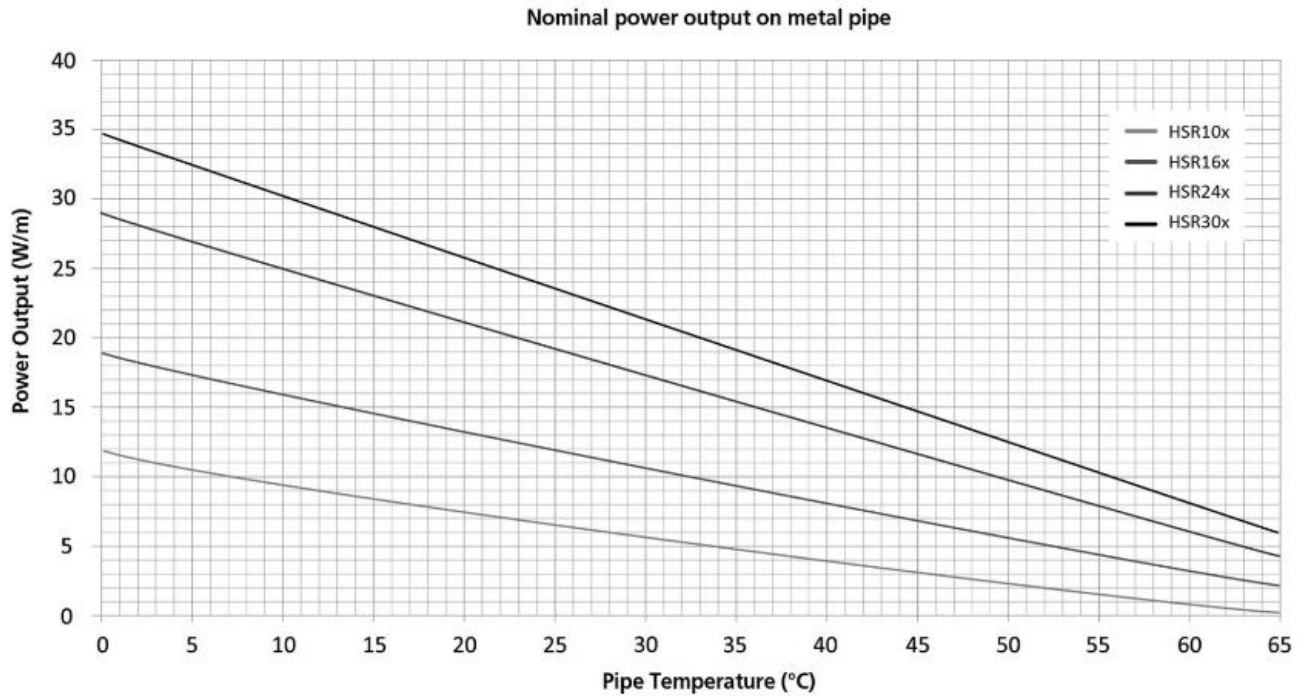

8. MAXIMUM CIRCUIT LENGTH

Maximum length (m) based on the start-up temperature (°C) and circuit breaker sizes (A). Curve C differential magnetothermic protection. Data considering a supply voltage of 230 Vac.

Model	Start-up Temperature °C	Circuit breaker					
		10A	16A	20A	25A	32A	40A
11A102	-20	84	134	155	155	155	155
	0	101	162	169	169	169	169
	10	131	193	193	193	193	193
11A162	-20	59	94	118	129	129	129
	0	71	113	141	142	142	142
	10	92	147	162	162	162	162
11A242	-20	42	67	84	104	111	111
	0	49	79	99	122	122	122
	10	66	105	131	137	137	137
11A302	-20	32	51	64	80	101	101
	0	32	51	64	80	102	113
	10	41	66	82	102	124	124

11A (HSR)



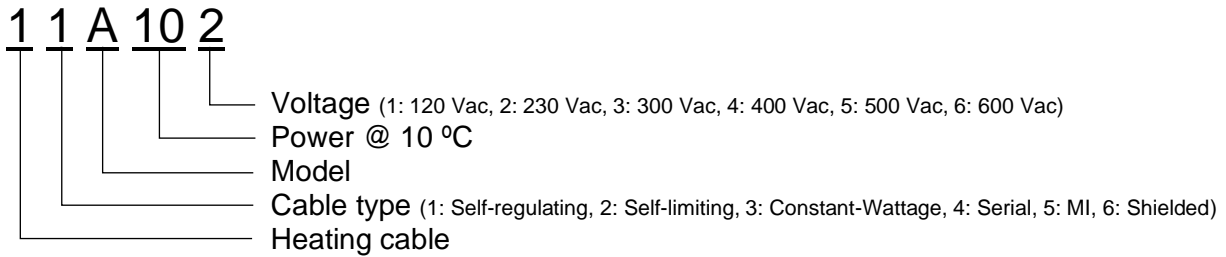

SELF REGULATING HEATING CABLE

9. CABLE CODE

1 1 A 10 2



10. APPROVALS / CERTIFICATIONS

Certification	Certification N.o	Certification	Certification N.o
	Baseefa15ATEX0109X		3033885
	11-AV2BO-0146		13/10027

11. TYPICAL INSTALLATION

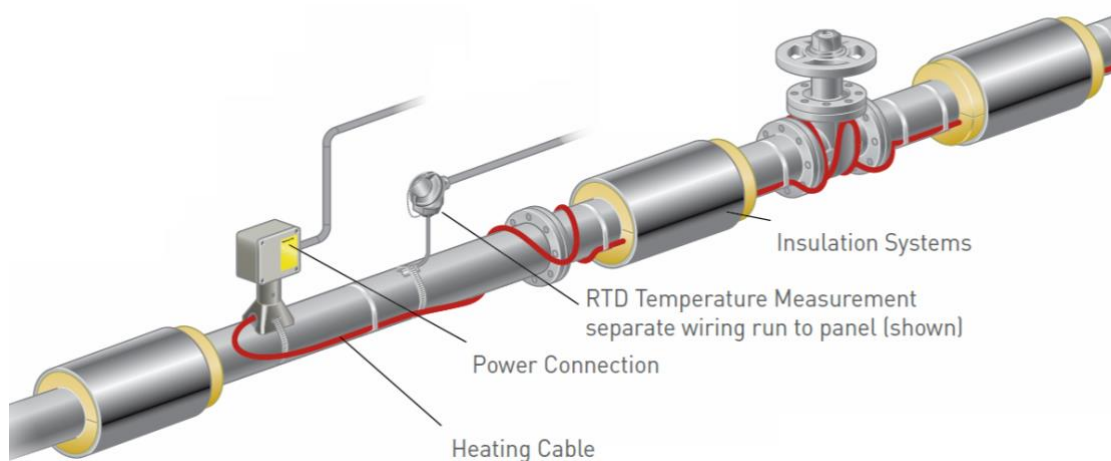



TRACELEC
HEATING SOLUTIONS

c/ Josep V. Foix 10 · 43007 Tarragona · Spain
+34 977 290 039 · ofertas@tracelec.es
www.tracelec.es